



-:The Green Campus:-
"A way towards Shaping Your Thoughts"



PROSPECTUS

Session (2023 -2024)

Asato Ma Sadgamaya, Tamaso ma Jyotirgamaya, Mrityor ma amritam gamaya
(From the unreal lead us to the real; from darkness lead us into light; from death lead us to immortality.)



+91-94354-79207



email@morigaoncollege@hotmail.com



Dist.: Morigaon P.O.: Morigaon
State: Assam (India) Pin : 782105.



Morigaon College
Affiliated to Gauhati University
NAAC Accredited B Grade Institute with CGPA 2.47

*Arts, * Science, * Commerce

CONTENT

Topics	Page. No.
GB President's Message	1
Welcome Note from the Desk of Principal	2
Our College	3
Vision, Mission & Motto	4
Infrastructure & Facilities	4-6
College at Glance	7
Departments	8-16
Non-teaching Staffs	17-18
IQAC	19
Committees, Cells & Centres	20-30
Rules & Regulations	31-32
GU Regulation on FYUGP	32-37
Subject selection Formula, List of Prerequisites & Requirements	37-42
Intake Capacity of Various Subject	43
Fees Structure	44

GB PRESIDENT'S MESSAGE

14th June 2023



It is my great honour to serve Morigaon College as President of the Governing Body.

With immense pleasure I welcome you all to this temple of learning that has been disseminating knowledge for more than five decades. Morigaon College was established on 1st July, 1964 and it is now one of the oldest institutions of higher education of undivided Nagaon district of Assam, presently located at Morigaon District. Since its inception in 1964 Morigaon College has been playing a leading role in spreading knowledge in the region.

The Governing Body, the dynamic faculty members and very supportive office staffs of the college are committed to impart value-based quality education to its students to accomplish its vision and mission. The college has a dynamic Principal and highly qualified faculty members in their respective fields of expertise. A good number of national and international conferences (offline and online), seminars and workshops have been organized by the college. Such events provide a variety of experiences to the students and young faculty members to inculcate skills such as leadership and team spirit which are helpful in their career building. Our faculty members have been able to publish good quality research work in National and International journals of repute. There has been always active and regular interactions held between faculty members, GB, alumni, guardians and students in the college. It is heartening to note that the NCC and NSS wings of the college are being very prominent nationally with lots of activities, achievements and services. The learning experiences in the campus pave a strong path for enhancement of overall development of our learners with wonderful Govt. support. Recently, the Hon'ble Chief Minister of Assam has taken his special initiative for adding Commerce stream in the college from this session and also granted Rs. 1.00 cr. for developing infrastructure of the science departments.

There's a lot to look forward to in this New Academic Session, 2023-24, including a big start of the NEP 2020 with 4YUG program. The college has a calendar of social events, sporting activities and opportunities to enjoy hobbies and find new interests.

We're here to support and guide you every step of the way.

My message to all of our young students is to grasp every opportunity to develop your skills, both within and outside your course. This is the start of a very great journey for all of you.

We look forward to seeing you soon. I wish you every success as you work towards realising your dreams.

With best wishes,

A handwritten signature in black ink, appearing to read 'J. Kalita'.

Prof. Jogen Ch Kalita,
MSc (Gau-Gold Medallist), PhD (LOND)
Dean of Faculty of Science & Head of the Department of Zoology
Gauhati University, Guwahati-781014,
E-mail: jogenck@yahoo.co.in, Contact no.: +918638322757



I am honored to welcome you to Morigaon College and extend my warmest greetings to you as the Principal of this esteemed institution. It gives me great pleasure to present to you the prospectus for the academic year 2023-24, offering you a glimpse into the rich academic, cultural, and extracurricular opportunities that await you at our college.

Morigaon College has always strived for excellence in education, and our commitment to providing holistic and well-rounded education remains unwavering. Over the years, we have nurtured countless students, helping them shape their futures and embark on successful journeys in various fields. We take immense pride in our dedicated faculty who work tirelessly to ensure that our students receive a quality education that not only equips them with knowledge but also instills in them a passion for lifelong learning.

Our college offers a wide range of undergraduate programs across diverse disciplines, enabling students to pursue their interests and chart their career paths. We emphasize a balanced approach to education, blending academic rigor with co-curricular and extracurricular activities, enabling students to develop critical thinking, problem-solving, and leadership skills.

Our state-of-the-art facilities and resources are designed to support your academic journey. From well-equipped classrooms to modern laboratories and a well-stocked library, we strive to provide a conducive learning environment that fosters intellectual growth and encourages research and innovation. We also offer various support services, including counseling, career guidance, and mentorship programs, to ensure that every student receives the necessary guidance and support to thrive academically and personally. Morigaon College is not just an academic institution; it is a vibrant community where students come together from various backgrounds and establish life-long relationships to learn and grow together.

As you peruse this prospectus, this year, we have come up with the NEP, 2020 course and structure, i.e. the Four Year Undergraduate Programme (FYUGP) keeping in conformity with the syllabus guidelines of Gauhati University. The multidisciplinary approach to curriculum, the institutionalisation of Academic Bank of Credit, the Multiple Entry-Exit Systems and other features of the NEP, 2020, have been well-incorporated in this year's graduation programme.

I invite you to join our esteemed institution and embark on an exciting educational journey at Morigaon College. Your dreams and aspirations will find wings here, and we will be there every step of the way to guide and support you in realizing your full potential.

Thank you for considering Morigaon College as your academic partner. I look forward to welcoming you into our vibrant community and witnessing your growth and success.

With warm regards,

Dr. Lila Kanta Barthakur
Principal
Morigaon College

OUR COLLEGE

Morigaon College, established on 1st July, 1964, is the oldest institution of higher education of Morigaon district of Assam. It has already completed 59 years as one of the premier institutions engaged actively in nurturing and disseminating ray of education in the region.

The college is located in the eastern part of the Morigaon Town-the headquarter of Morigaon district. It is 70 km away from Dispur, the state capital of Assam. The nearest railway station is Jagiroad (23km) and nearest airport is LGBI airport, Borjhar, Guwahati (96Km).

Since its inception, in the first two decades, the college imparted education only in Arts stream. The science stream was introduced in 1985 and set to open up a new dimension by facilitating congenial environment to pursue higher education in science and cultivating scientific temperament. In 2002 the college introduced several vocational and job-oriented courses like Computer Application, Industrial Fish and Fisheries and Functional Hindi. In 2012 Commerce Stream in degree level has been introduced with a view to fulfilling the need of higher education in Commerce for its aspirants. This fulfilled the long felt absence of an academic centre for higher education in Commerce in the whole region. In the face of the current socio-economic background

the UGC has reoriented and reshaped its policies and programme to make the Indian higher education system career - oriented with focus on quality and excellence. It is in keeping with the spirit of UGC that Morigaon College introduced certain career oriented courses like Functional English, Translation and Proficiency and Entrepreneurship in Small Scale Industries from the academic session 2004-05. It is expected that the professionally qualified graduates with solid knowledge on the core disciplines and enterprises will have better chances for recruitment in service, industry and self-employment sectors.

The college has earned the pride of introducing Postgraduate Programme in Geography in 2017 and Zoology in 2018. In 2018, the college has started another professional course on Food Processing Technology. In the U.G. level, Sociology (General Course) has been introduced in the same year. Currently, there are thirty five Add-on Courses running in the college.

Gauhati University has recognized Chemistry Laboratory of the college as highly capable of facilitating advance research works. Besides, in 2020 college has introduced Bachelor of Computer Application and Bachelor of Journalism and Mass Communication, Food Processing.



VISION, MISSION & MOTTO

Vision:

To promote Knowledge through quality education with a view to developing the human resource of the region for contributing to the process of nation-building.

Mission:

- ❖ To augment the new generation for contributing to the future knowledge-economy.
- ❖ To empower the socially, economically and educationally marginalize sections of the society.
- ❖ To uplift the rural masses through effective education.

Motto:

*Asato Ma Sadgamaya
Tamaso Ma Jyotirgamaya*

Mrityor ma amritam gamaya

(From the unreal lead us to the real; from darkness lead us into light; from death lead us to immortality.)

INFRASTRUCTURE AND FACILITIES OF THE COLLEGE

The college has its Administrative Block, Academic Block, full-fledged Computer Laboratory, Auditorium, Conference Hall, Seminar Hall, Narendra Nath Keot Science Block, Guru Charan Medhi Library, Play Ground & Indoor Stadium, Shooting Range, Swahid Mudra Patar Boys' Hostel, Swahid Giribala Deka Girls' Hostel and New Girls' hostel, Gymnasium Centre, Day Care Centre, Rain Water Harvesting system, Botanical

Garden, Canteen, Cafeteria, Green House, Horticulture Garden, washrooms and Ramps for differently-abled students, and Digital Classrooms that makes teaching-learning process a enlightening experience.

Gurucharan Medhi Library:

Guru Charan Medhi Library, named after the founder principal of the college, is well equipped and highly resourceful. It is an RFID based fully automated library using SOUL2.0 software, introduced in 2016.

Facilities and services provided by the library:

- ❖ Total collection of the library is 40,100 books including texts and references;
- ❖ 26 numbers of Journals/Magazines;
- ❖ 6 daily News Paper; more than 6,000 e-journals
- ❖ 1, 35,000 e-books through 'N-LIST' subscription and Research thesis of PhD holders in the college including book published by the faculty members of the college.
- ❖ Separate 'E-Resource cum Internet Browsing Section' for the students for limited Internet uses.
- ❖ 'Book Bank' facility for poor and needy students
- ❖ Reprography facility is available instantly at a nominal price
- ❖ Institutional repository is also available

Departmental Library:

Apart from the central library, each department has its own library with a good

collection of books, both texts and references for the benefit of students and faculties.

A.K. Gohain Memorial Hall:

It is an ICT enabled hall for conferences, meetings, seminars and classes for students.

College Auditorium:

The college has an auditorium with seating capacity of 1,200, equipped with acoustic sound system.

Seminar Hall:

The college has three sophisticated seminar halls with the estimated capacity of 80 seats each.

Gymnasium:

There is a gymnasium in the college campus with modern equipments.

Indoor Stadium:

The Indoor Stadium is providing adequate facilities to students for indoor games, namely, badminton, table tennis, volleyball, shooting range.

Games and Sports:

There are various facilities for games and sports in the college. The college has a rich stock of sports tools and equipments and a big play ground for outdoor games.

KKHSOU Study Centre:

A study Centre of Krishna Kanta Handique State Open University was started in the year 2007. It offers various undergraduate, postgraduate and certificate courses on distance mode.

Research Facility:

All the departments of Science stream have been well equipped with laboratories. The departments have published research-oriented journals for the benefit of the students.

Boys' and Girls' Common Room:

There are well-furnished common rooms for boys, girls and transgender students.

National Service Scheme (NSS):

The college has a unit of the NSS which encourages the students for social service. It inculcates social consciousness and a sense of responsibility, discipline and dignity of labour among the youths.

National Cadet Corps (NCC):

The college has an NCC Unit, both for boys and girls of 8th APBN Assam Battalion, Nagaon, which is affiliated to the Directorate of NCC, Shillong.

Green House:

A Green House was set up in 2007-08 in collaboration with Anti-Global Warming Society, Morigaon. It preserves the indigenous plants species for educational purposes. It aims at motivating the students and the local community for generating awareness for environmental protection.

Centre for Training on Competitive Examinations:

The college set up a centre for coaching and training on competitive examinations in 2016. This offers training courses on APSC, UPSC, TET, Banking Services and other competitive examinations.

Students' Welfare Fund:

The college facilitates Krishna Kanta Handique Scholarship and financial aid for the meritorious students having weak financial background.

Course on Spoken English & Spoken Hindi:

The college provides special courses on Spoken English & Spoken Hindi with a view to budding students' professional communication proficiency and personality development

Centre for Yoga and Meditation:

The centre endeavors to improve the spiritual and mental health of the college family through Yoga and meditation.

College Canteen:

College has a well-furnished canteen for students, teachers and guests.

Adopted Village:

The college has five adopted villages under Unnat Bharat Abhiyan-

namely, Oujaribori, Mayanguri, Borigaon, Solmari, Mikir Gaon and Bhayaguri. In addition two more villages, namely, Moridhali Pathar and Gerakhowa are adopted for all round development.

Coaching on Sports:

Morigaon College provides coaching for various sports such as volley ball, cricket, shooting, and badminton etc. in the college premises.

Vermicompost Plant:

A vermin-compost plant has been set up in the college campus under the initiative of Department of Botany for the production of Bio-fertilizer using in-campus bio-degradable materials.

Career Guidance and Counseling Cell:

There is facilities for career guidance and counseling for students of the college. The faculty-in Charge of the cell organizes career guidance and counseling program regularly. For the benefit of the students, External Resource Persons are invited.



*Bhupen Hazarika Statue
Morigaon College*

THE COLLEGE AT A GLANCE

Name	Morigaon College																
Date of Establishment	1 st July, 1964																
Affiliation	Gauhati University																
UGC Regd	2(F)&12(B)																
NAAC Accreditation Award	<table border="1"> <thead> <tr> <th>Year</th> <th>Round</th> <th>Grade</th> <th>CGPA</th> </tr> </thead> <tbody> <tr> <td>2005</td> <td>1st</td> <td>'B'</td> <td>73</td> </tr> <tr> <td>2011</td> <td>2nd</td> <td>'B'</td> <td>2.35</td> </tr> <tr> <td>2019</td> <td>3rd</td> <td>'B'</td> <td>2.47</td> </tr> </tbody> </table>	Year	Round	Grade	CGPA	2005	1 st	'B'	73	2011	2 nd	'B'	2.35	2019	3 rd	'B'	2.47
Year	Round	Grade	CGPA														
2005	1 st	'B'	73														
2011	2 nd	'B'	2.35														
2019	3 rd	'B'	2.47														
Founder Principal	Late Gurucharan Medhi																
Former Principals	<ul style="list-style-type: none"> a) Sri Narendra Nath Keot b) Sri Prabhu Narayan Mazumdar (i/c) c) Dr. Harekrishna Deva Sarmah 																
Present Principal	Dr. Lila Kanta Barthakur																
Programmes Offered	<ul style="list-style-type: none"> a) Higher Secondary (Arts & Science) b) Four Year Under Graduate Programme <ul style="list-style-type: none"> 1. Degree in Stream <ul style="list-style-type: none"> i. Arts. ii. Science iii. Commerce 2. Degree in Discipline <ul style="list-style-type: none"> i. Computer Application ii. Food Processing iii. Journalism and Mass Communication. c) Post Graduate Programmes under Gauhati University <ul style="list-style-type: none"> i. Geography ii. Zoology d) PGDM- Disaster Management e) Certificate Courses 																
Distance Education	K. K. Handique Study Centre (Degree & P.G Course)																
Other Facilities	<ul style="list-style-type: none"> a) Career counseling b) Placement & Training c) Scholarship 																
Nos. of Teaching Staff	53 (Permanent) 38 (Contractual)																
Nos. of Non-teaching Staff	21 (Permanent) 36 (Temporary)																
Address for Correspondence	Morigaon College, Morigaon, Assam 782105																
Contact No	03678 240268																
E-mail ID	morigaoncollege@hotmail.com																
Website	www.morigaoncollege.edu.in																

DEPARTMENTS

Department of Anthropology

“Strive to promote knowledge, understanding and skill.”

The department of Anthropology under both science and arts stream started in 1994. The department started with three teachers and one laboratory bearer. The first batches of Higher secondary and TDC students appeared in the final examination in 1996. From 1996 onwards numbers of students in anthropology is increasing rapidly and are passing with flying colours. Each year 35 to 65 numbers of students are carrying letter marks in the subject. The major course in TDC class was introduced in the year 2009 with ten seats. Till date many students have completed higher studies and engaged in different jobs.

SI No	Name	Designation	Qualification
1	Dr. Dipali Das Talukdar	Assistant Professor	M.Sc., M. Phil, PhD(G.U), B.T., B. Music (Vatkhand)
2	Bibeka Nanda Sarma	Assistant Professor	M.Sc., M. Phil.
3	Dr. Nilofar Jasmin	Assistant Professor & HOD	M.Sc., M. Phil, PhD (G.U), B.Ed
4	Kabita Das	Assistant Professor	M.A

Department of Assamese

“অসমীয়া ভাষা শিক্ষণত শ্ৰৱন, কথন, পঠন, লিখন দক্ষতাৰ বিকাশ সাধন।”

ভাৰতৰ পূৱাংশত অসমৰ প্ৰধান ভাষাতথা ৰাজ্যিক ভাষা হৈছে অসমীয়া। অসমীয়া ভাষা-সংস্কৃতি আৰু সাহিত্যৰ উত্তৰণৰ ক্ষেত্ৰত মৰিগাঁও মহাবিদ্যালয়ৰ অসমীয়া বিভাগে পূৰ্বৰে পৰা উদ্যোগ লৈ আহিছে। ১৯৮৭ চনৰ পৰা অসমীয়া বিষয়ত গুৱাহাটী বিশ্ববিদ্যালয়ৰ অধীনত স্নাতক সন্মান পাঠ্যক্রম আৰম্ভ হয়। ছাত্ৰ-ছাত্ৰীৰ বৌদ্ধিক, শৈক্ষিক, মানসিক মৰ্গদৰ্শন ক্ষেত্ৰত অসমীয়া বিভাগে সন্মানীয় দায়বদ্ধ। বৰ্তমান ৬ গৰাকী শিক্ষক আৰু ১৮৫ জন ছাত্ৰ-ছাত্ৰী বিভাগটোৰ মূলশক্তি।

SI No	Name	Designation	Qualification
1	Dr. Nibedita Saikia	Assistant Professor & HOD	M.A. Ph.D.(DU)
2	Samutjal Saikia	Assistant Professor	M.A. M. Phil
3	Hemaprabha Rabha	Assistant Professor	M.A. B.Ed
4	Utpal Mech	Assistant Professor	M.A., M. Phil
5	Dr. Dibya Jyoti Sarma	Assistant Professor	M.A.Ph.D.(GU)
6	Nandita Talukder	Assistant Professor	M.A. M. Phil.

Department of Botany

“Go Green”

The Department was established in the year 1985 and is located in the 1st Floor of the Science Block. The aim of the Department is to establish a Centre for imparting knowledge, enhancing skills and cultivating attitudes among the students, in order to achieve academic and human excellence. The Major Syllabus was introduced in the year 1997 and the course was started with one room for theory and one for practical classes. Since 1997 until now i.e., 2022, all together total 22 no. of batches of Major/Honours students have passed out from the department with flying colours. The department has an Herbal Garden with various types of medicinal plants, Green house and a Horticulture Garden. Students after completion of the degree course can opt for Master Degree Programme in Botany, Microbiology, Biotechnology, Life Science, Environmental Science and one can join in the State Forest Service, Central Rubber Board of India, Tea Board of India, ICAR, NBRI and various agencies as well as Indian Forest Service after clearing APSC and UPSC.

SI No	Name	Designation	Qualification
1	Mrs. Ami Devi	Associate Professor & HOD	MSc.
2	Mr. Trideep Chetia	Assistant Professor	M.Sc., MPhil
3	Dr. Jayanta Borkakoti	Assistant Professor	M.Sc., PhD, Post Doc.
4	Mr. Kashyap Das	Assistant Professor	M.Sc (PhD ongoing)
5	Mr. Ankur Jyoti Bora	Assistant Professor	M.Sc., PGDCA

Department of Chemistry

“Tamso Ma Jyotirgamaya (तमसोमाज्योतिर्गमय)”

The Department of Chemistry was established in the year 1985 along with the Science stream in the oldest building from where the college started its ambitious journey. B.Sc. Honours Course in Chemistry was introduced in 2012. The aim of the department is "to enrich the students in the nearby area with both theoretical and experimental knowledge of chemistry". Recently, with a fund received from the RUSA and K.K. Handique (Morigaon College Branch), the new building has been preserved and is being used to teach undergraduate and higher secondary students. The Department is housed with one research laboratory, three general laboratories, one preparation room, three class rooms, one seminar hall and one staff room.

SI No	Name	Designation	Qualification
1	Dr. Arunima Sarma	Associate Professor	MSc., PhD
2	Dr. Swagata Baruah	Assistant Professor	MSc., PhD
3	Dr. Rituraj Das	Assistant Professor	MSc., PhD
4	Dr. Murshid Iman	Assistant Professor	MSc., PhD
5	Dr. Nashiour Rohman	Associate Professor	MSc., PhD

Department of Commerce

"Bringing back the past, unlocking the present, building the future."

The department was come into existence on 1st August 2012 with two specializations (Accountancy & Management) under the affiliation of Gauhati University. The Department of Commerce is a leading and the pioneer Centre of commerce education in the entire Morigaon district. Till now the department has successfully created 08 outgoing batches. The department has been established with the core objective of imparting the business education to the young generation so that every student may keep up with the most recent advancements on a local, national, and international level in the business ecosystem.

SI No	Name	Designation	Qualification
1	Mr. Kangkan Jyoti Nath	Assistant Professor	M.com
2	Dr. Pranjeet Das	Assistant Professor & HOD	M.Com, Ph.D. (BHU)
3	Ms. Malaya Devi	Assistant Professor	M.Com

Department of Computer Application

"Lead the advancement of computer science among students to prepare them for life-long learning."

The Department of Computer Application of Morigaon College comes in to existence on 2008. The Department offers BCA course, BSc. (H) Computer Science and Generic Elective for students of other courses. The department has attained unprecedented heights and stands on par excellence. The department has proven its academic prowess and success with an extensive range of courses offered at the Undergraduate level. The department of Computer Applications was set up with the objective of providing the latest quality education in the field of computer Applications. The Computer Applications department introduced vocational Computer Application and Information Technology courses to BA program students and Computer Science Generic electives courses to Hons students. Later in 2020, the department introduced the Bachelor of Computer Application (BCA) course under Gauhati University.

SI No	Name	Designation	Qualification
1	Mr. Bulbul Das	Assistant Professor	BCA, MCA, SLET
2	Mr. Abdul Malik	Assistant Professor	MCA

Department of Economics

“GLOCALIZATION- Think Global...Act Local”

The Department of Economics is one of the oldest and leading departments in the Arts Stream of Morigaon College. Since its inception, the Department has been discharging its roles and responsibilities for the interests of the students of Economics in particular and the whole student community in general. The Department was established in 1964 under the affiliation of Gauhati University. At the time of its establishment there were 01 faculty and 09 of students. The Honours / Major courses were started in this department in 1977.

SI No	Name	Designation	Qualification
1	Parag Jyoti Mahanta	Assistant Professor	M.Sc., M. Phil.
2	Dr. Chandan Sharma	Assistant Professor & HOD	M.A., M. Phil., PhD.(MSSV)
3	Dr. Budhen Kr. Saikia	Assistant Professor	M.A., PhD (G.U)
4	Mrinmoyee Baishya	Assistant Professor	M.Sc., M. Phil

Department of Education

“Achieving excellence together”

Department of Education was established in the year 1971. The founder head of the department was Mrs. BaniBaruah. The major course in the department was started in 1989. The department has four teaching and one non-teaching staff faculty. The department has been playing a pivotal role in imparting quality higher education in UG level since 1971. The department offers three years Honours Course in B.A. programme under the CBCS system. The Department has been providing different certificate course for the college students since 2021-22. Education as department aims at helping the students in all round development. The department strives to provide knowledge, skills, attitude and values of different thrust areas. The thrust areas include Educational Psychology, Educational Technology, Educational Management, Educational Philosophy, Educational Sociology, Teacher Education, Education and Development and Educational Statistics.

SI No	Name	Designation	Qualification
1	Dr. Birat Kr. Panyang	Assistant Professor	M.A., PhD(G.U.)
2	Dr. Kalyan Das,	Assistant Professor & HOD	M.A., M. Phil., B.Ed., PhD(G.U)
3	AugustinTerang	Assistant Professor	M.A
4	Ruma Begum	Assistant Professor	M.A

Department of English

"Come, Learn and Create."

The Department of English was started in the year 1964 with three renowned educationists of the region, namely, Prabhu Narayan Mazumdar, Kuladhar Nath and Naba Kanta Bordoloi. Initially the Department offered B.A. Pass Course English (Compulsory Course) to the Degree Students. In the year 1996, Major Course was introduced and since then it has been offering English Major/Honours. Before the introduction of CBCS, the Department offered Functional English (Compulsory Course) to the B.Sc students. The Department started to offer Certificate Course in "Spoken English" from the year 2018 as one of its best practices then. This Departmental initiative was later institutionalized by the College and now every Department offers atleast two certificate courses. The Department has organized a Webinar on "Eco-Criticism and Covid-19 Pandemic: A Literary Survey" on 6 July, 2021. It has also organized an International Seminar on "Green Literature and Philosophy: Text, Contexts and Arguments" on 20 and 21 December, 2022.

SI No	Name	Designation	Qualification
1	Dr. Diganta Kr. Nath	Associate Professor & HOD	M.A(English),M.A(Linguistics),M. Phil., PhD (T.U),PGCTE,PGDTE
2	Ajijur Rahman	Assistant Professor	M.A. ,M. Phil
3	Dr. Ajit Konwar	Assistant Professor	M.A., M. Phil, PhD
4	Dr. Saradashree Choudhury	Assistant Professor	M.A., M. Phil., PhD(T.U)
5	FatehaSultana	Assistant Professor	M.A

Department of Food Processing (Agri.)

"Hands-On Learning for a Career in Food Processing"

The Department of Computer Science is one of the youngest departments of the Morigaon College. It was established in the year 2019 with the introduction of B.Voc program in Food Processing under the University Grants Commission's (UGC) Skill Development Initiative. The department of Food Processing Agri is focused on educating and training students in the field of food processing and agriculture, with the goal of developing professionals who are well-equipped to meet the challenges of the industry. Department offers bachelor's degree in Food Processing Agri, as well as certificate courses for those seeking specialized training in areas such as Human Nutrition, Food Preservation and Food Packaging.

SI No	Name	Designation	Qualification
1	Ms. Subarna Deb	Assistant Professor	Msc in Food Science And Technology

Department of Geography

"Making Geographical knowledge accessible to all"

It was in the year 1994 that the department of geography, Morigaon College was established. The department received permission to teach geography in degree level (general) course from Gauhati University in 1994 and got government concurrence in 1995. The department also got affiliation for part – II degree courses in the year 2000. Major course was introduced in the year 1996 and Post Graduate courses were introduced in the year 2017.

SI No	Name	Designation	Qualification
1	Hahi Ram Lahkar	Associate Professor &HOD	M.A., Ph.D. (S.U.)
2	Dr. Hemanta Kr. Nath	Associate Professor	M.A. M.Ed., PhD (S.U.)
3	Dr. Mainu Goswami	Assistant Professor	M.A., M. Phil., Ph.D. (NEHU)
4	Dr. Pranab Jyoti Sarma	Assistant Professor	M.A., M.Ed., Ph.D.(NEHU)
5	Jayanta Kr. Das	Assistant Professor	M.A.
6	Rajib Malo	Assistant Professor	M.A.
7	Punam Gogoi	Assistant Professor	M.A.

Department of Hindi (हिंदी विभाग)

"आओ मिलकर हाथ बढ़ाए, हिंदी को जन-जन तक फैलाए।"

हिंदी हमारी आन है, हिंदी हमारी शान है

हमारी चेतना वाणी का हिंदी शुभ वरदान है।"

मोरीगांव महाविद्यालय में हिंदी विभाग की स्थापना सन 1996 ई. में हुई। प्रारंभ में हिंदी विषय को द्वितीय भाषा और मातृभाषा के रूप में गौहाटी विश्वविद्यालय के पाठ्यक्रम के अनुरूप रखा गया, परंतु विद्यार्थी की मांग और आवश्यकता को ध्यान में रखते हुए सन 1999 ई. में गुरु विषय (Major subject) का पाठ्यक्रम भी शुरू किया गया। राष्ट्रनिर्माण की प्रक्रिया में योगदान देने के लिए क्षेत्र के मानव संसाधन को विकसित करने की दृष्टि से गुणवत्तापूर्ण शिक्षा के माध्यम से ज्ञान को बढ़ावा देना है।

SI No	Name	Designation	Qualification
1	Jugal Ch. Nath	Assistant Professor & HOD	M.A., M. Phil
2	Dr. Chayanika Saikia	Assistant Professor	M.A., M. Phil.(GU) PhD(TU)
3	Dr Kushal Mahanta	Assistant Professor	M.A, PhD
4	Prankrishna Bharali	Assistant Professor	M.A.

Department of History

"Shraddavan Lobhate Jnanam"

The Department of History was established in the year 1964. The major course was introduced in the year 1998. The Department of History right from its inception has been

aiming to promote quality education among the students. The aim of the department is: "Endeavour towards the knowledge of the past and build a sustainable future"

SI No	Name	Designation	Qualification
1	DeepakKalita	Assistant Professor & HOD	M.A., M. Phil., B. Ed
2	Suman Das	Assistant Professor	M.A., M. Phil
3	Raj BallavNath	Assistant Professor	M.A

Department of Mass Communication and Journalism

Department of Mass Communication and Journalism of Morigaon College take the pride as the pioneering Mass Communication Department in middle Assam. At present, Department offers one degree programs and two certificate courses. These include BA in Mass Communication and Journalism and the certificate course on videography and Certificate on Screenplay Writing and Filmmaking. As of now, the Department has one faculty member who is expert in different disciplines of communication studies. The Department fosters an intellectual environment that stimulates creativity, inclusiveness and a global perspective.

SI No	Name	Designation	Qualification
1	Mr. Khanjan Kumar Nath	Assistant Professor	M.Phil

Department of Mathematics

"Acquire knowledge of Mathematics and apply in life."

The Department of Mathematics was established in 1985 and one of the pioneer departments for the study of Mathematics at the Undergraduate level in the Morigaon District of Assam and its adjoining areas, having a highly qualified, experienced, and dedicated faculty. Since the major course's inception in 1992, the department has made significant contributions to mathematics education in Morigaon district. The aim of the Department is to set the department as a postgraduate and research department so that it becomes easily accessible for locals as well as others. The major thrust areas for research are Dusty Plasma, Mathematics Education, Meteorology, Intuitionistic fuzzy near ring, and Topology.

SI No	Name	Designation	Qualification
1	Dr. Simarekha Bhagowati	Assistant Professor	MSc., PhD
2	Dr. Ranjit Kumar Kalita	Associate Professor	MSc., PhD
4	Mr. Prafulla Kumar Bora	Assistant Professor	MSc., PhD
6	Miss Upashana Gogoi	Assistant Professor	MSc., PhD
7	Dr. Pradip Saikia	Associate Professor	MSc., PhD
8	Mr. Shamim Akhtar	Assistant Professor	M.Sc.

Department of Philosophy

“Knowledge that Enlightens All”.

The foundation year of Morigaon College and Department of Philosophy is same and it's 1964. College founder Principal Sjt. Gurucharan Medhi was also founder teacher of our department. Before 1999, Philosophy department was provided only pass course facility. But in 1999 our department successfully introduced Major Course and now it has been continuing to till date. Now our department provides Honours course as well as Generic course as new CBCS rules and regulations. Now there are around 80 nos of students in both Honours and Generic courses.

SI No	Name	Designation	Qualification
1	Dr. Nilamani Phukan	Associate Professor	M.A, Ph.D
2	Dr.Sanjib Hussain Thakuria	Associate Professor & HOD	M.A.,M.Phil.,M.Ed.,PGDDE., Ph.D(CMJU)
3	Jamuna Bordoloi	Assistant Professor	M.A.
4	Anamika Sharma	Assistant Professor	M.A.

Department of Physics

“Tamaso Ma Jyotirgamaya”

The department of Physics was established in 1985 with Mr. D. Sarma as the founder Head. The major course was started in 1999 and since then Department has been contributing a lot towards physics education, not only in Morigaon district, but also in the central Assam. The vision of the Department is in building up an environment in the Physics education as well as scientific temperament among the student community along with the nearby society. Students of this department are seen to pursue their higher studies in institutions like IITs, State and Central universities etc. The department consists of a staff room, five laboratories (with a dark room) and two class rooms. The add-on (Certificate) courses are repairing of household electrical Appliances, Vedic Astrology from astrophysical point of view, Basic carpentry.

SI No	Name	Designation	Qualification
1	Mrs. Kabita Sarmah	Associate Professor & HOD	MSc.
2	Mr. Babul Talukdar	Associate Professor	M.Sc.
3	Mr. Nurul Islam Ali Ahmed	Associate Professor	M.Sc.
4	Dr. Hemanga Jyoti Sarmah	Asst. Professor	PhD

Department of Political Science

“Maximum Effort, Maximum Knowledge, Maximum Realization.”

The department of Political Science is dedicated to excellence in teaching and service. As a department, it offers solid foundation and broad understanding of the discipline and allows students for substantive interest at local, regional and national level. The department was established in 1984 with both Major and pass Course. Currently the department has four experienced and dedicated faculty members. The department has maximum numbers of student enrolment within the college.

SI No	Name	Designation	Qualification
1	Dr. Hemalata Sarma	Associate Professor, Vice Principal	M.A. PhD
2	Dr. Achyut Kumar Das	Assistant Professor &HOD	M.A., PhD
3	Dr. Pallavi Hazarika	Assistant Professor	M.A. PhD (NEHU)
4	Dr. Jayasree Nath	Assistant Professor	M.A., M. Phil PhD (JNU)

Department of Zoology

“Live and Let them Live.”

Our department namely “Department of Zoology,” in Morigaon College, was established in the year 1985 as a pioneer center of teaching in Zoology / Life Science / Physiology/Biochemistry/Ecology/FisheryBiology/Taxonomy/Immunology/ Toxicology/IFF/BBT in Assam/ North Eastern Region of India. The aim of the Department is to aware and teach pupil for better Zoological understanding for benefit of the society. The department has a glorious tradition of quality education contributing significantly to the human resource development and catering to the manpower need of various Aquaculture, Pisciculture, Sericulture and Forestry, operating in the state. The primary objective of the department is to impart quality education in the subject of Zoology as a basic science and its applied branches to the students from rural Morigaon with a minimum fee.

SI No	Name	Designation	Qualification
1	Dr. Dhananjay Kusre	HOD and Associate Professor	Ph.D., M.Phil.
2	Dr. Abdul Quium Osmani	SR. Assistant Professor	Ph.D., M.Phil., B.Ed
3	Miss DilsJoree	Assistant Professor	M.Sc (P.hD Pursuing)
4	Miss Madhubanti Das	Assistant Professor	M.Sc (P.hD Pursuing)
5	Miss Rijuana Ahmed	Asst. Professor	M.Sc, M.Ed
6	Miss Manjita Modak	Asst. Professor	MSc.
7	Mr. Ramashankar Bordoloi	Asst. Professor	MSc.

NON-TEACHING STAFF

Library Staff	
Librarian:	
Dr. Alakesh Roy, M.L.I.Sc., M. Phil	
Library Assistant:	Bhupen Ch. Bhuyan JagadishNath
Non-teaching Staff	
Senior Assistant:	Haren Medhi,
Junior Assistant:	Jiban jyoti Bora Amarjyoti Nath Madhurjya Sarmah Sabita Sarma Partha Pratim Bordoloi Biswajit Bordoloi (IQAC) Nilutpal Nath(IQAC)
LDA:	Madhab Bora
Krishna Kanta Handique State Open University Staff:	
Co-ordinator:	Jugal Chandra Nath
Junior Assistant:	Kabita Bordoloi; Prasanta Bora
Supporting Staff:	Sarat Hazarika Juganta Kumar Nath
Laboratory Bearers:	
Chemistry Lab:	Kusheswar Medhi
Zoology Lab	Rabin Medhi
Zoology Office Staff	Naren Ch. Kalita
Botany Lab	Ghanendra Nath Cheniram Medhi
Physics Lab	Thanu Ram Medhi

Anthropology Lab	Suren Haldar
Geography Lab	Nabin Hazarika
Education Lab	Jitram Das
Commerce	Bhagadutta Nath
Grade-IV Employees	
	Arun Chandra Bora Pradip Kr. Nath Dipali Saikia Pinku Hazarika Binod Kr. Nath
Electrician	Bipul Bora
Night Chowkidars	
	Puspa Hazarika Bhaben Hazarika Jayanta Kalita
Gardener	Juganta Kr. Nath
Cook (Boys' Hostel):	Prabin Bora
Metron (Girls' Hostel):	Manju Saikia
Cook (Girls' Hostel)	Sunali Deuri (Temporary) Raju Patar (Temporary) Bhabani Devi (Temporary) Minati Konwar (Temporary)
Gate Keeper	Kishore Kr. Nath
Cleaner	Sonali Medhi Muna Basfor (Girl's Hostel)



INTERNAL QUALITY ASSURANCE CELL (IQAC)

For performance, evaluation, assessment and accreditation and quality upgradation, Morigaon College has formed an Internal Quality Assurance Cell (IQAC) on 2nd June, 2008. The basic objectives of the IQAC are:

- ❖ To ensure continuous improvement in the entire operations of the institution.
- ❖ To ensure stakeholders connection with the institution.
- ❖ To develop a system for conscious, consistent and catalytic improvement in the performance of the institution.

Chairperson : Dr. Lila KantaBarthakur

Coordinator : Dr. Ranjit Kumar Kalita

Assistant Coordinator : Dr. Ajit Konwar

Members :

- ❖ Dr. ArunimaSarmah, Associate Professor, Chemistry
- ❖ Dr. DhananjayKusre, Associate Professor, Zoology
- ❖ Dr. Hahiram Lahkar, Associate Professor, Geography
- ❖ Dr. Nilofar Jasmin, Assistant Professor, Anthropology
- ❖ Mr. ParagjyotiMahanta, Asstt. Professor, Economics
- ❖ Mr. Achyut Kr. Das, Asstt. Professor, Pol.Science

Management Member : Dr. Alokesh Roy

**Member from the
Society/Alumni** :

- ❖ Mr. MileswarPatar, Social Worker
- ❖ Mr. DalimPhukan, Senior Journalist, Assam Tribune

**Member
(Administrative Officer)** :Mr. Garga Mahon Das, ADC, Morigaon

**Member
(Industrialist)** : Mr. Pradip Bhuyan Proprietor, M/S Big Banyan
Tree, Hengrabari, Guwahati

Student Member(s) : President of the Student Union Body, Morigaon College

Stakeholder Member : Mr. Bharat Nath (F/O Mr. Samion Nath, B.Sc. First Sem,
(Math (H))

COMMITTEES, CELLS AND CENTRES

1. ACADEMIC COMMITTEE

Chairperson : Principal
Convener : Co-coordinator, IQAC
Members : All Head of the Departments

Functions :

- ❖ Looks after all the academic matters and UGC related activities.
- ❖ Prepares annual academic calendar and prospectus of the college.
- ❖ Prepares schedules for examinations.
- ❖ Conducts student union body election, college week and all different types of activities.

2. GRIEVANCE REDRESSAL COMMITTEE

Advisor : Dr. Hemalata Sarma, Vice Principal,

Convener : Dr. Nilofer Jasmin

Members :

- ❖ Prafulla Kumar Bora
- ❖ Dr. Mainu Goswami
- ❖ Dr. Budhen Kumar Saikia
- ❖ General Secretary, Students Union Body
- ❖ Bhaskar Bezbaruah, Advocate, Morigaon Bar Association

Functions

- ❖ To check the tendency and grievances relating to smoking, drug, alcohol etc. of the student.
- ❖ To introduce smooth and confidential procedure of receiving any grievances from the students, guardian and employee of the institution.
- ❖ To look after undue/unauthorized Juvenile activities and to conduct awareness programme relating to Juvenile Justice.
- ❖ To conduct awareness programme on Legal Right of men and women.

3. SEXUAL HARASSMENT REDRESSAL CELL

Advisor : Dr. Dipali Das Talukdar

Convener : Mr. Parag Jyoti Mahanta

Members :

- ❖ Dr. Pallavi Hazarika
- ❖ Mr. Jugal Chandra Nath

- ❖ Dr. Nibetita Saikia
- ❖ Dr. Arun Kumar Nath (Superintendent of STHG Civil Hospital)

Function :

- ❖ To prepare complaint redressed procedure.
- ❖ To conduct programmes relating to women welfare and promotion of gender amity.
- ❖ To keep record of every gender discrimination/physical or verbal sexual harassment case.
- ❖ To provide consultation to everyone who want to discuss issues related to gender discrimination.
- ❖ To provide support service (legal and health) to the victimized with help of college authority.
- ❖ To keep confidential all the details of the case handled.
- ❖ To organize student counseling to program to prevent sexual harassment.

4. ANTI-RAGGING COMMITTEE

Convener : Mr. Prafulla Kumar Bora

Members :

- ❖ Kabita Sarma
- ❖ Dr. Chandan Sharma
- ❖ Dr. Saradshree Choudhury
- ❖ Nandita Talukdar
- ❖ Dr. Pranjeet Das
- ❖ OC, Morigaon Police Station

Functions :

- ❖ To ensure compliance with the provisions of Regulations as well as the provisions of any law for the time being in force concerning ragging.
- ❖ To monitor and oversee the performance of the Anti-Ragging Squad in prevention of ragging in the institution.

5. RESEARCH FACILITATION COMMITTEE

Advisor : Dr. Arunima Sarma

Convener : Dr. Saradashree Choudhury

Members

- ❖ Dr. A. Q. Osmani
- ❖ Upasana Gogoi
- ❖ Dils Joree
- ❖ Utpal Mech
- ❖ Dr. Rituraj Das

Functions :

- ❖ To encourage the teacher and student to develop research culture and to keep all records of research project
- ❖ To arrange and conduct seminar/workshop/symposia etc
- ❖ To study the best practices (Teaching and learning) of other colleges.
- ❖ To find new idea of the best practices what will be beneficial for college stakeholder.
- ❖ To survey local community needs.
- ❖ To publish research works.
- ❖ To develop research infrastructures in college campus.

6. ICT MANAGEMENT AND DEVELOPMENT COMMITTEE

Convener : Dr. Pallavi Hazarika

Members :

- ❖ Dr. Pranab Jyoti Sarma
- ❖ Dr. Hemanga Jyoti Sarma
- ❖ Dr. Alakesh Roy
- ❖ Mr. Bulbul Das
- ❖ Mr. Amar Jyoti Nath

Functions :

- ❖ To develop and maintain computer networking system of the college.
- ❖ To regular update of the College web-site.
- ❖ To Arrange self-finance course (earn and learn scheme) and provide training total employees of the college.
- ❖ To take up necessary step towards introduction of various computer related courses.

7. LIBRARY MANAGEMENT COMMITTEE

Convener : Dr. Alakesh Roy

Members :

- ❖ Dr. Nilamoni Phukan

- ❖ Dr. Nilofar Jasmin
- ❖ Dr. Sanjib HussainThakuria
- ❖ Md. Ajjur Rahman
- ❖ Trideep Chetia
- ❖ Rajib Malo

Functions :

- ❖ To advise and review library policies for instruction, resources, services, and the facility.
- ❖ To advise regarding library services, especially innovation, for the campus community.
- ❖ To discuss budgetary issues for books, journals, databases, media, etc. of the college.

8. GAMES AND SPORTS MANAGEMENT COMMITTEE

Convener : Dr. Hemanta Kumar Nath

Members :

- ❖ Nandita Talukdar
- ❖ Dils Joree
- ❖ Kashyap Das
- ❖ Jayanta Kumar Das
- ❖ Dr. Pradip Saikia
- ❖ Games Secretary (Major & Minor)

Function :

- ❖ To encourage student participation in state/national level sport events.
- ❖ To promote women sports.
- ❖ To provide optimum indoor and outdoor sports facilities.
- ❖ To arrange coaching for different games for stakeholders.
- ❖ To promote yoga/gymnastics.

9. CANTEEN AND HOSTEL MANAGEMENT COMMITTEE

Advisor : Mrs. Ami Devi

Convener : Dr. Diganta Kumar Nath

Members :

- ❖ Subarna Dev
- ❖ Dr. Ajit Konwar
- ❖ Deepak Kalita
- ❖ Dr. Saradshree Choudhury
- ❖ Vice President, Students' Union Body

Functions :

- ❖ To fix standard rate of items stakeholders and nature of item of canteen.
- ❖ To ensure hygienic quality of Canteen/Hostel items and availability round the year.
- ❖ To look after the accommodation and infrastructure facilities of hostels.
- ❖ To call tender periodically for smooth functioning.
- ❖ To look after the behavioral conduct of student inside the canteen and Hostel.
- ❖ To take up necessary steps for improving common room, during hall, indoor games, gardens hostel library, publication culture etc in hostel premises.
- ❖ To take up necessary steps for arranging proper security service, drinking water, sanitation facilities, waiting shed for guardians etc.
- ❖ To prepare rules and regulation for hostel borders.
- ❖ To constitute student Sub-committees to conduct internal hostel affairs.

10. STUDENT SUPPORT AND PROGRESSION CELL

Convener : Dr. Sanjib HussainThakuria

Members :

- ❖ Dr. Birat Kumar Panyang
- ❖ Babul Talukdar
- ❖ Parag jyoti Mahanta
- ❖ Dr. Achyut Kumar Das
- ❖ Mrinmoyee Baishya

Function :

- ❖ To introduce mentoring system in the college.
- ❖ To identify weak students.
- ❖ To organize tutorial classes for the weakerstudents.
- ❖ To arrange facility for differently able students.
- ❖ To provide financial support to economically weaker students.

11. PRESS & PUBLIC RELATION CELL

Convener : Dr. Achyut Kr. Das

Members :

- ❖ Jugal Chandra Nath
- ❖ Samutjal Saikia
- ❖ Khanjan Kishor Nath

Functions :

- ❖ To arrange for the publication of events, activities etc. of the college in print media (News Paper etc.) and electronic media.
- ❖ To develop a cordial relationship among teachers, students and guardians
- ❖ To involve parents/guardians in different activities of the college.
- ❖ To maintain record of the alumni of the institution and to assure active involvement of the alumni in various matters related to the college.

12. HEALTH AWARENESS CELL

Advisor : Dr. Simarekha Bhagawati

Convener : Mr. Babul Talukdar

Members :

- ❖ Madhubanti Das
- ❖ Dr. Swagata Baruah
- ❖ Dr. Pradip Saikia
- ❖ Anamika Sarma
- ❖ Dr. ArunNath, Superintendent of STHG Civil Hospital Dr. ArunimaSarma

Functions

- ❖ To arrange First-Aid basic training.
- ❖ To conduct awareness programme to promote health and hygiene of the student as well as teachers and other staff of the College.
- ❖ To organize Blood Donation Camp.
- ❖ To conduct awareness programme on AIDS, CANCER in collaboration of local NGOs, College extension activity cell or any other Govt. organizations.
- ❖ To observe World Health Day, World Red Cross Day, World AIDS Day, World Anti-Tobacco Day etc.

13. EXTENSION ACTIVITY CELL

Advisor : Dr. Hahi Ram Lahkar

Convener : Dr. Dhanajoy Kusre

Members :

- ❖ Ajjur Rahman
- ❖ Dr. Kalyan Das
- ❖ Dr. Jayasree Nath
- ❖ Dr. Dibya Jyoti Sarma
- ❖ Augustin Teron
- ❖ President, Students' Union
- ❖ Dr. Arun Nath, Superintendent of STHG Civil Hospital

Functions :

- ❖ To take up village development schemes such as adult education, look after cleanness local area, school adaptation programme, community service and programme related to integration.
- ❖ To bring awareness on environment, disaster etc. among the common people.
- ❖ To exercise relief work during the time of natural calamities.
- ❖ To Provide self-financing consultancy programme (earn and learn scheme) to the Stakeholders.
- ❖ To take up Cultural activities.

14. CAREER GUIDANCE CELL

Convener : Dr. Abdul Quium Osmani

Members :

- ❖ Ajjur Rahman
- ❖ Dr. Budhen Kumar Saikia
- ❖ Dr. Hemanga Jyoti Sarma
- ❖ Suman Das
- ❖ Dr. Chayanika Saikia
- ❖ Madhubanti Das

Function :

- ❖ To conduct survey among students on their career options.
- ❖ To arrange programme to create awareness about the importance of higher education.
- ❖ To arrange coaching classes on CAT, MAT, APSC, UPSC etc.

- ❖ To conduct orientation programmes for new-comers.
- ❖ To organize programme for personality development, soft skills and communication skills.
- ❖ To provide job information.
- ❖ To maintain records of past students regarding their career.

15. MENTORING CELL

Convener : Dr. Nilamani Phukan

Members :

- ❖ Dr. Jayanta Borkakoti
- ❖ Mrinmoyee Baishya
- ❖ Augustin Terang

Functions :

- ❖ To provide support and guidance on teaching, research, the mentoring of students.
- ❖ To support the professional advancement of the mentees by relaying experiences and knowledge of mentors in the key performance areas of teaching, research and support service.
- ❖ To motivate the students and develop the confidence to take up challenging tasks in their lives and help society in nation-building.

16. INTELLECTUAL PROPERTY RIGHTS CELL

Convener : Dr. Arunima Sarma

Members :

- ❖ N. I. Ali Ahmed
- ❖ Dr. Dibya Jyoti Sarma
- ❖ Dr. Jayasree Nath
- ❖ Dr. Achyut Kumar das
- ❖ Rituraj Barua

Functions :

- ❖ To create an awareness about IPR and guide the stakeholders.
- ❖ To impart training on future endeavors regarding patent filing processes.
- ❖ To do novelty checks on the IPs of the stakeholders.
- ❖ To encourage faculty members, Research scholars and students to involve patentable works.

17. INNOVATION AND ENTREPRENEURSHIP CELL

Convener : Dr. Chandan Sharma

Members :

- ❖ Dr. Ajit Konwar
- ❖ Dr. Jayanta Borkakoti
- ❖ Mr. Samutjal Saikia
- ❖ Dr. Mriganka Shekar Pathak
- ❖ Dr. Gulam Omar Ahmed

Functions :

- ❖ To bring out entrepreneurial flair in students.
- ❖ To make students understand entrepreneurial attitude and entrepreneurial skills.
- ❖ To provide them with a platform which gives willa number of innovative opportunities to develop the entrepreneur in them.

18. INSTITUTIONS INNOVATION CELL (IIC-MORIGAON COLLEGE)

Sl No	Name of the Member	Member Type (Teaching/ Non-Teaching/External Expert)	Key Role/Position Assigned in IIC
1	Dr. Ajit Konwar	Teaching	President
2	Dr. Achyut Kumar Das	Teaching	Vice-President
3	Prof. Krishna Gopal Bhattacharyya	IP/ Patent Expert (External)	Member
4	Mr. PradipBhuyan	Alumni Entrepreneur Expert (External)	Member
5	Mr. Rishi Jain	Industry& Entrepreneur Expert (External)	Member
6	Mr. Prahlad Borkataki	FI & Bank Expert (External)	Member
7	Dr. Jayanta Borkakoti	Teaching	Convener
8	Dr. Chandan Sharma	Teaching	ARIIA Coordinator
9	Dr. Ranjit Kumar Kalita	Teaching	NIRF Coordinator
10	Dr. ArunimaSarma	Teaching	IPR Coordinator
11	Dr. Hemanta Kumar Nath	Teaching	Innovation Activity Coordinator
12	Mr. Parag Jyoti Mahanta	Teaching	Innovation Activity Coordinator
13	Mrs. Sangeeta Gope	Teaching	Internship Coordinator
14	Dr. Jayashree Nath	Teaching	Social Media Coordinator
15	Dr. Dibya Jyoti Sarma	Teaching	Startup Activity Coordinator
16	Dr. Sanjib Hussain Thakuria	Teaching	Coordinator, Incubation Centre
17	Dr. Dhananjoy Kusre	Teaching	Coordinator, Innovation Cell

Functions :

- ❖ To create an innovation promotion eco-system on campus by promoting innovation within the institution through a variety of channels.
- ❖ To carry out different innovation and entrepreneurship-related tasks outlined by Central MIC in a time-limited manner.
- ❖ To spotlight and honour inventions, and to share success tales.
- ❖ To plan regular workshops, seminars, and encounters with entrepreneurs, financiers, and other professionals while building a network of mentors for young innovators.
- ❖ To build a network with national entrepreneurship development organisations and peers.
- ❖ To develop an institution's innovation portal to highlight cutting-edge work done by the faculty and students of the institution.
- ❖ To plan idea competitions, mini-challenges, etc. with the participation of various industries.

19. TEACHING LEARNING CENTRE

Coordinator : Dr. Pranab Jyoti Sarma

Assistant Coordinator : Dr. Kalyan Das

Members :

- ❖ Dr. Alakesh Roy
- ❖ Dr. Chayanika Saikia
- ❖ Dr. Dibya Jyoti Sarma
- ❖ Mr. Trideep Chetia
- ❖ Ms. Upasana Gogoi
- ❖ Mr. Bulbul Das

Functions :

- ❖ To periodically provide a questionnaire to faculty members in order to determine their needs for teaching and learning.
- ❖ To plan highly tailored Faculty Induction Programmes in educational psychology, socioeconomic issues, and political issues for all newly appointed faculty at the Assistant Professor level.
- ❖ To plan refresher courses at a higher level and that are more discipline-specific for the faculty members who are active in teaching in order to improve their abilities, continuously improve their knowledge, and expose them to new advances.
- ❖ To carry out specially created programmes that will allow the faculty to take advantage of the quickly expanding information and communication technology support (ICTS) for both teaching and research.

20. NEP IMPLEMENTATIONS TASK FORCE

President : Dr. Lila Kanta Barthakur

Convener : Dr. Budhen Kumar Saikia

Members :

- ❖ Dr. Sanjib Hussain Thakuria
- ❖ Dr. Sima Rekha Bhagawati

Functions :

- ❖ To execute, coordinate and communicate with the Directorate of Higher Education with regard to NEP-2020.

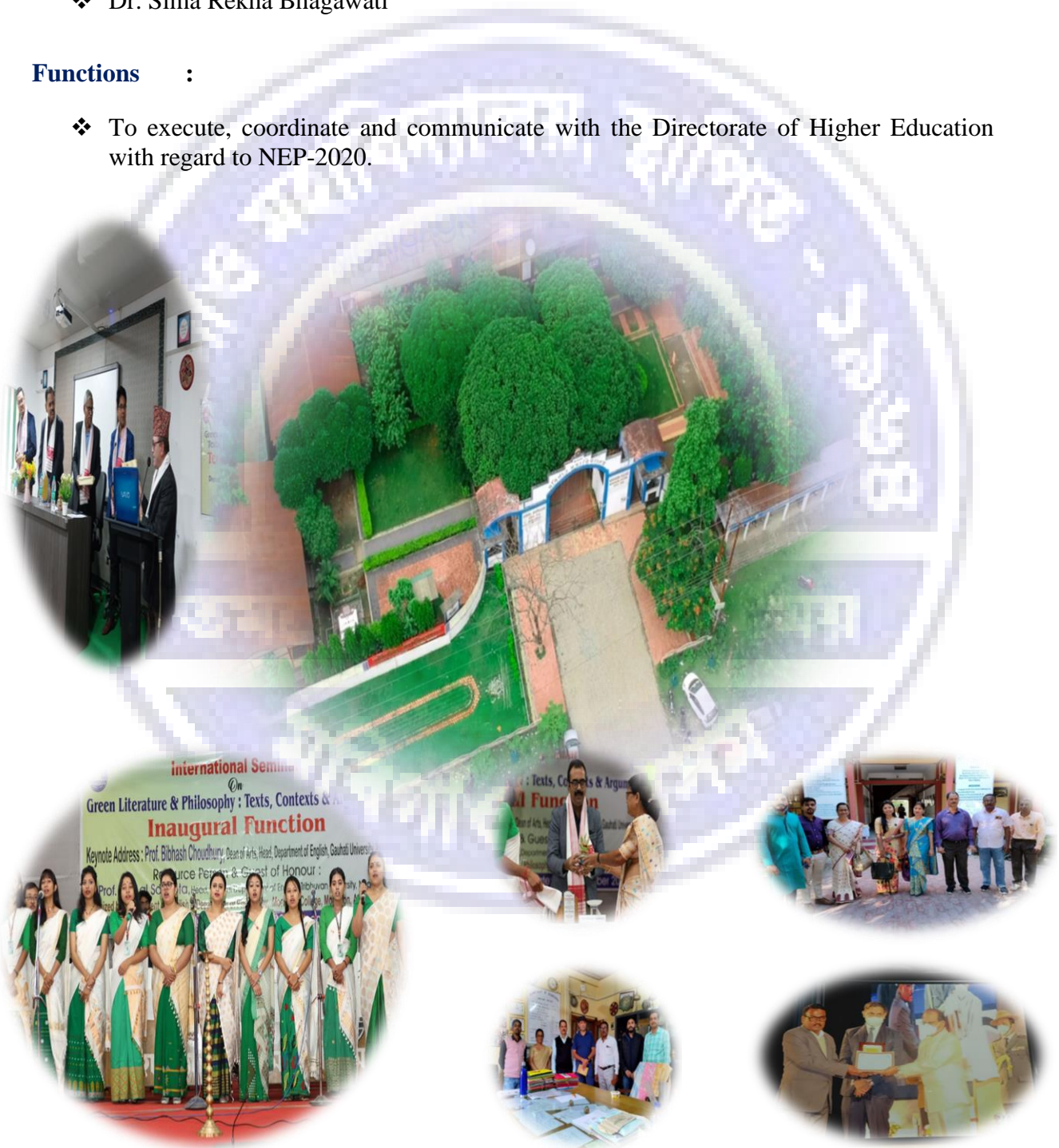

RULES AND REGULATION

Rules and Regulation of the College

College Uniform: Boys must be dressed in white shirt and black formal pant. Close fitting & low waist/ mid-rise/ low-rise pants will not be considered. Shirts/pants must be the appropriate length not too long or short. The dress code for girls is blue salwar, white kameez and blue dupatta. Short fitting dress & leggings/pants will not be considered. Salwar-kameez must be the appropriate length – not too long or short. Only maroon coloured blazer or cardigan during winter for both boys and girls is recommended. Jacket, jeans and T-shirts are not a part of the dress code. A college logo (which shall be supplied by college authority during admission period) has to be affixed by each student on shirt pocket position (for boys) and kameez on right arm position (for girls). All students must maintain the dress code of the college. No student shall be allowed to attend classes, festivals or any functions without proper uniform.

Rules concerning student conduct: Each student is required to attend allotted lectures, tutorials, and practical classes. Use of mobile phone by students is strictly prohibited in the college campus. Exhibition or introduction of any political party-emblem in the college premises is forbidden. Disciplinary action will be taken against a student resorting to such acts. Disciplinary action will also be taken against any student resorting to acts calculated to cause public nuisance, disturbance of public peace, law and order.

Any of the following acts by students shall be considered as a major breach of discipline: (a) Habitual unpunctuality, (b) Any form of immoral behaviour, (c) Use of intoxicants, drugs etc. in the college premises or in any of the attached hostels. (d) Resorting to violence of any kind.

Anti-Ragging: Ragging is strictly prohibited in the College premises as per UGC rule. Morigaon College has an Anti-ragging Committee and Anti-ragging Squad.

Library Rules: The library is kept open 9.30 a.m. to 4.00 p.m. throughout the year on all working days except on public holidays. Membership of the library is open to the students, teachers and non-teaching staff of the college. Newly admitted will have to fill up a library membership form and have to submit it along with two copies of recent passport size coloured photograph. Students can issue/ return books themselves in the 'Self Service Kiosk' automatically with the RFID library card.

General Rules and Regulations:

A student shall not be allowed to appear in the higher Secondary/Degree semester end examination as a regular candidate if she/he has not attended a minimum of 75% of the total lectures delivered in each subject. A student with attendance between 75% and 65% will be declared as Non-collegiate. Then on-collegiate students will be allowed to appear in the examination if he/she takes casual admission. Students attending less than 65% of the total lectures delivered in each subject shall be considered as dis-collegiate.

Dis-collegiate students must not be allowed to appear in examination at any cost. The dis-collegiate students will be allowed to appear in examination next year if one takes fresh admission. The calculation of attendance takes place after all the classes are closed. Failed/backed/ dropped students in any examination will be allowed to appear in the same examination after getting casual admission. Sessional examinations are conducted in the months of October (During Odd Semester) and in April (During Even Semester). For continuous evaluation of the performance of the students, the college conducts unit tests and terminal examinations.

REGULATIONS OF GAUHATI UNIVERSITY FOR TDC SEMESTER SYSTEM

Attendance of Students:

Students must **have 75%** attendance. The attendance of all courses including the Skill Enhancement courses shall be counted, and accounted for in full while determining if the student has met the minimum attendance norms of Gauhati University.

In case, a student fails to have at least 75% attendance, he/she will not be allowed to sit for End-semester examination and will be needed to repeat the concerned semester after the successful completion of the subsequent semesters for earning the deficit credits.

Any student securing less than 75% attendance due to medical reasons will have to apply form medical leave in a prescribed form (within seven days from the date of absence) along with relevant documents/certificates etc from an authorized medical practitioner. However, after accounting for medical leave granted, the minimum attendance will still have to be

75%. If it still remains below 75%, the student will not be allowed to sit in end semester examination. Such consideration will be subject to the condition that the student must have at least 60% attendance.

For absence due to participation in prescribed co-curricular activities (eg. NCC/NSS/Youth Festival/ Sports etc.), the claim for CCA leave will have to be made in prescribed form and supported by authenticated certificate(s) from concerned authorities. However, the minimum attendance after accounting for CCA leave granted will still have to be 75%.

GU REGULATION ON FYUGP

The Four-Year Undergraduate Programme (FYUGP) of Gauhati University is as per UGC's Curricular Framework, published in November 2022. The course structure of FYUGP is built on the Choice-Based Credit System (CBCS).

Duration:

Under the NEP's FYUGP, it is a 4-year degree programme.

Exits & Entries:

In the FYUGP, one has choice to exit from the programme thrice—after one year, after two years, and after three years. If one exits the programme after one year, one gets a certificate. If one exits after two years, one gets a diploma. If one exits after three years, one gets a Bachelor's Degree, and finally if a student completes the whole 4-year, one gets a Bachelor's Degree (Honours).

Honours and Major:

Under the CBCS, we either have Bachelor's Degree (Honours) or a regular Bachelor's Degree. In FYUGP, we get a Bachelor's Degree with Major after 3 years and a degree with Major & Honours after 4 year.

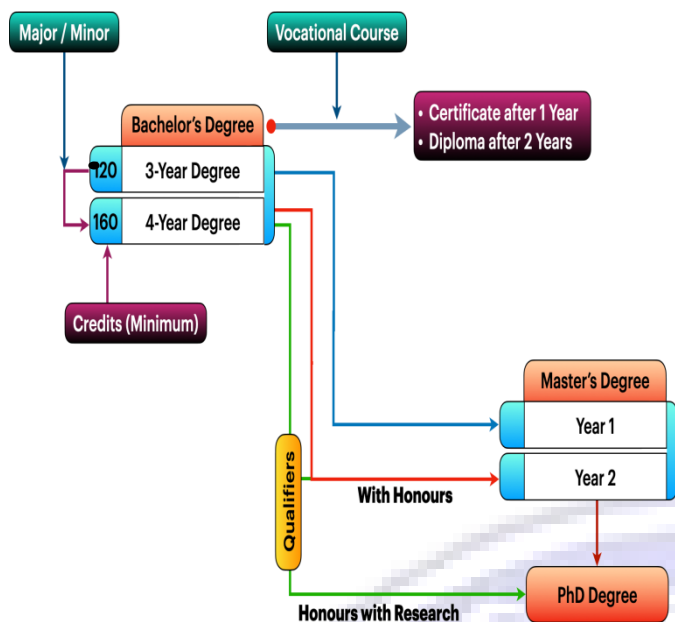

Progression:

If a student exits the FYUGP after 3 years, s/he will need to take admission into the first year of a Master's programme, which is a 2-year degree programme. However, if a student fully completes an FYUGP, s/he needs to take admission into the second year of a Master's programme and needs to complete only one year to get a Master's Degree. Under CBCS, there were no such pathways.

Progression to Doctoral Studies:

Once a student takes admission into a Master's programme either after 3 years of the Bachelor's programme or after FYUGP, one will be able to take admission into a Doctoral programme leading to the Degree of PhD. However, if a student is exceptionally good, one can directly take admission into a Doctoral programme right after the FYUGP, by passing the Master's programme.

Basically, there are two parts of a course under the FYUGP– (a) **Core Courses** and (b) **Common Courses**. As the name suggests, different students study different core courses and all students study the common courses.

First Year (Semester I & II):

In the first year, one studies three different core subjects—one paper of each subject per semester. Besides, one needs to study a host of common subjects that we have designed as per UGC's Curricular Framework. Details of these courses are described in this booklet.

Second Year (Semester III & IV):

Semester III

In the third semester, one will usually continue with the same core subjects that have already been chosen in the first year and again study some common subjects. In the third semester, one will also take a step forward to study the favourite subject by **declaring** one of the core subjects as a **Major** subject and other two as **Minors**. However, the structure of the programme remains same as in first & second semesters.

Semester IV

From Semester IV onwards, one will primarily study the Major subject by taking at least four papers, some of which may be elective depending on the subject concerned.

As the programme structure in the third semester is same as the first & second semesters, one will have the option of changing the Major in fourth semester to anyone of the other two Minors as well, even if one has already declared a Major in the third semester. However this has the condition that the new Major subject of choice has vacancy.

Third Year:

In the third year, one will continue to study the Major subject to complete a full set of 15 papers in Majors.

Fourth Year:

If one intends to progress to the fourth year, s/he will be devoting the time in studying advanced courses which will be at the level of initial Master's degree papers. Besides, one will also have the opportunity of engaging into research work with the faculty members.

Besides the above, there are some more unique features of the FYUGP. They are

Free Credits:

From third to sixth semesters, one will have time for 4 free credits per semester, which one can utilise for having more Minors. They can also come handy, if one had changed a Minor subject in between.

Double Major:

If a student is ready to do some more hard work, s/he can take some extra online courses (from designated sources only) related to the Minors and can then convert one of the Minors to a second Major by the time one completes 3 / 4 years of study. This is over and above the first Major. In this case, one will have a Bachelor's Degree with Double Majors.

FYUGP degrees & course structures:

The FYUGP at GU is designed to offer two types of Bachelor's Degrees to the students at the end of the successful completion of the programme —

- (i) Bachelor's Degree in a Stream and*
- (ii) Bachelor's Degree in a Discipline.*

The word **stream** here refers to Arts, Science, Commerce, and Management. In case of a degree in a stream, the student studies a multitude

of different subjects, usually mixing different disciplines, which leads to a truly multidisciplinary degree. While in case of a degree in a discipline, the student is confined to a certain sets of disciplines. However, in both cases, the student studies equal number of courses (i.e. papers) —so there is no age of any kind to either of the two types of degrees.

For both the types of degree programmes, course-wise, the whole FYUGP is divided into two parts—

- (i) Core Courses and*
- (ii) Common Courses.*

The minimum credit allocation for a 3year programme is 84 credits in Core Courses and 36 credits in Common Courses, which comes to a total of minimum 120 credits for a 3-year programme. With the fourth year, the minimum credit requirement becomes 160. A student can however earn up to a maximum of 132 credits in a 3year programme and 176 by the fourth year.

Core courses:

The Core Courses determine the ultimate degree, diploma, or certificate a student will earn at the end of third (or fourth) year, second year, or first year, respectively. The performance in the Core Courses will also determine the grade of the student in the final examinations. Total minimum credit requirement is 84 for the Core Courses, which translates to 21 courses (i.e. papers) with a credit allocation of 4 per course (paper). A student will need to study at least three Core subjects.

The Core Courses have to be chosen among a plethora of subjects offered (see the section on Subject

Details) for both the types of degrees, respectively. In case of a Bachelor's Degree in a Stream, the components of the Core Courses are Major and/or Minors, while in case of a Bachelor's Degree in a Discipline, there are no Majors and Minors.

Major and Minors:

In case of a Bachelor's Degree in a Stream, a student either chooses a Major and Minors or just Minors from among the subjects. In any case, a student needs to complete 21 courses or 84 credits by the third year. Please see the examples that we have given in this booklet. A Major course **MUST** carry a minimum credit of 60 and a Minor course should carry a minimum credit of 12.

Usually, for majority of the students, the Core Course will consist of one Major and two Minors. But if a student desires, using the free credits (as described earlier), s/he can easily complete a third Minor as well.

Common courses:

The common courses are to be studied by all students alike and altogether they carry total credits of 36 over a 3-year period. These courses are further divided into five (5) sub-categories, as described below.

Semester III:

In the third semester, one will usually continue with the same core subjects that have already been chosen in the first year and again study some common subjects. In the third semester, one will also take a step forward to study the favourite subject by **declaring** one of the core subjects as a **Major** subject and other two as **Minors**. However, the structure of the programme remains same as in first &

second semesters.

Multi-disciplinary Courses:

These are 3-credit courses spanning over five different groups of subjects—
(i) Natural and Physical Science, (ii) Mathematics, Statistics, and Computer Applications, (iii) Library, Information, and Media Sciences, (iv) Commerce and Management, and (v) Humanities and Social Sciences. The levels of the courses are of Class XII.

Each student need to take at any three papers, each with 3 credits from the five subgroups during Semesters 1-3.

Ability Enhancement Courses (AEC):

This is an 8 credit course covering Modern Indian Languages (MIL) and English Usage (Communication).

Each student needs to complete two papers of 4 credits each one from English Usage and other from the group of MIL, especially designed for this purpose. These courses have to be taken during Semesters 1-2.

Skill Enhancement Courses (SEC):

These are various skill courses with total credit allocation of 9. In our structure, we have four skill courses out of which a student needs to study the first skill course of 3 credits in the second Semester. And then the rest three skill papers, each having 2 credits need to be studied during Semesters 4-6.

Value Added Courses (VAC):

The VAC courses will come from four sub groups (i) Understanding India, (ii) Environmental Science, (iii) Digital

and Technological Solutions, and (iv) Health & Wellness, Yoga Education, Sports, and Fitness. All together they will have a credit allocation of 6.

Each student will have to take any two papers, each of 3-credits, from any three groups during Semesters 1 & 3. Here one paper from the Environmental Science group is *compulsory* except if the student takes a core course on Environmental Science.

Internship:

All students are to carry out an Internship with a credit allocation of 4. The internship can be carried out in any semester during Semesters 3 - 6. As internships are meant to be done during semester breaks, they will not interfere with other classes.

The fourth year:

In the FYUGP, the fourth year is at par with the first year as a Master's programme, as a student can directly take admission in to the second year of a Master's programme after the successful completion of the FYUGP.

In the fourth year, a student has to complete one compulsory paper on Research Methodology (REM) in the Semester VII, which is a 4-credit theory paper. The rest of courses will consist of Advanced Core Courses and a Dissertation.

Core Course options:

Degree in a Stream:

The following diagrams show three different options which a student can choose to complete a 3 year programme under the FYUGP.

Option 1: In this option, the student chooses a Major course and two Minor courses. With this option, the student will have 12 free credits, which s/he can utilize. if s/he wants to.

Option 2: In the second option, the student has utilized these 12 free credits to complete one more Minor.

Option 3: The third option is when the student does not want any Major but wants to study all three courses equally. This option will be known as No Major (NOM) option. In this option, the student studies one paper from each of the three subjects in each semester from Sem 1 to 6.

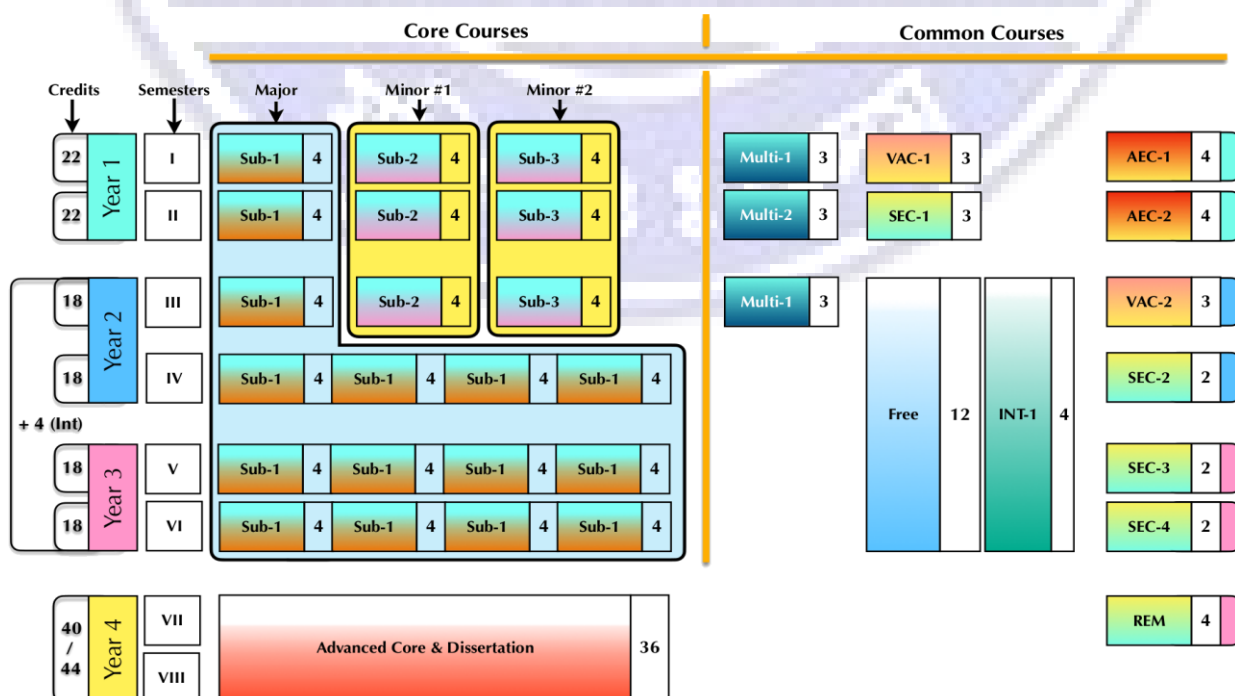

Core Courses

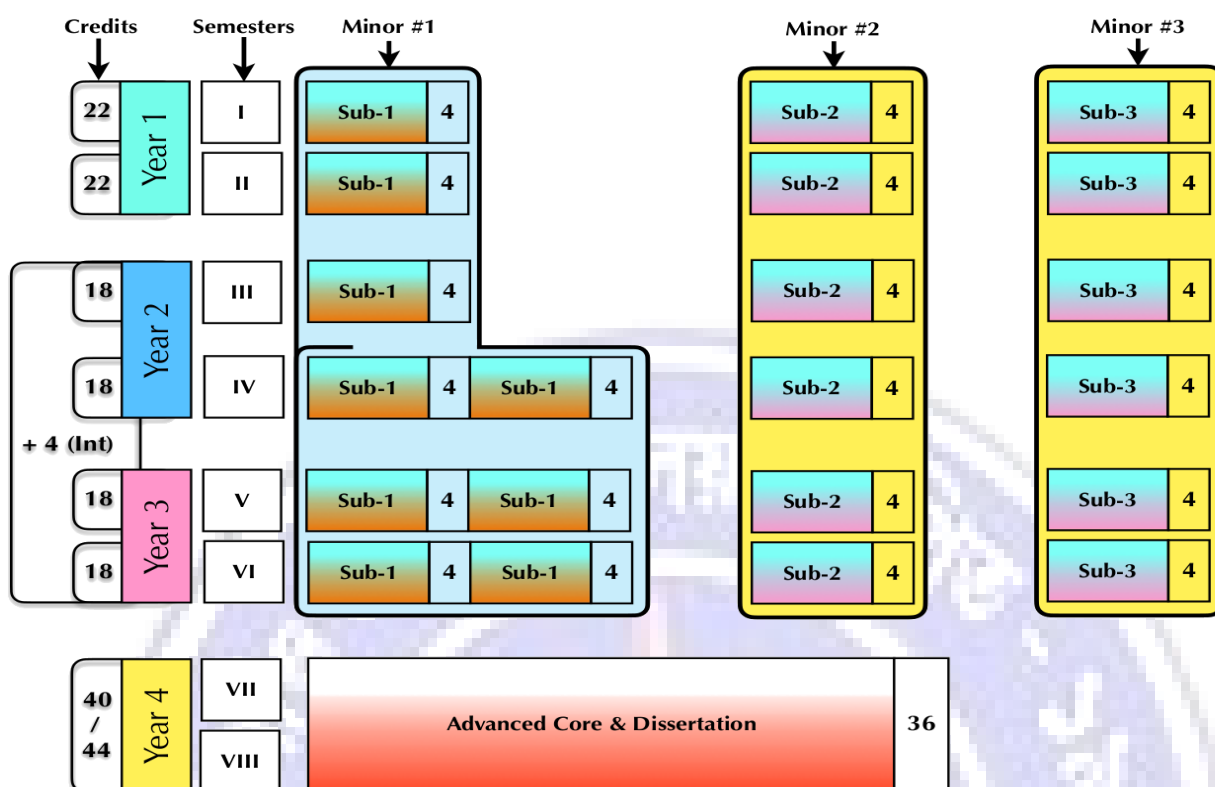

SUBJECT SELECTION FORMULA

1. Degree in Stream (Arts)

A. Core Course

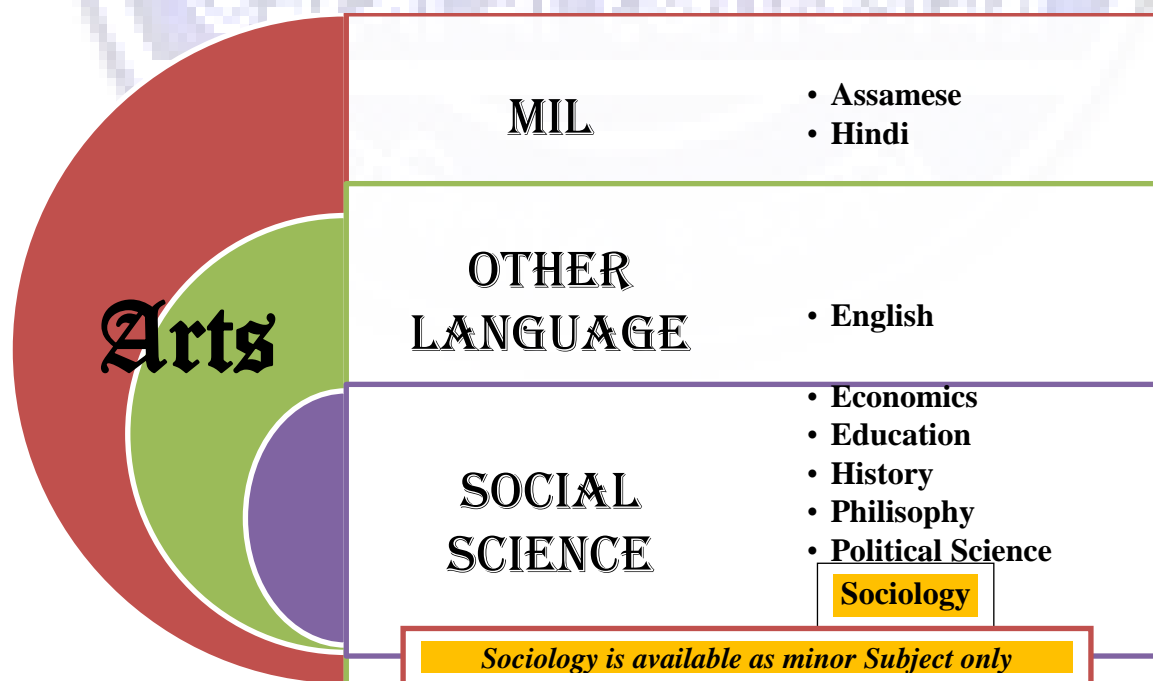

LIST OF PREREQUISITES & REQUIREMENTS

Stream: Arts		
MIL		
Subject	Prerequisites	Requirements
Assamese	Assamese(X level) for minor & (XII level) for Major	None
Hindi	Hindi (XII level)	

Stream: Arts		
Other Language		
Subject	Prerequisites	Requirements
English	English (XII level)	None

Stream: Arts		
Social Science		
Subject	Prerequisites	Requirements
Economics	None	None
Education		
History		
Philosophy		
Political Science		
Sociology		

2. Degree in Stream (Science)

A. Core Course

Science			
Physical Science	Biological Science & Anthropology	Earth & Environment Science	Computer & Information Science
Physics	Anthropology	Geography	Computer Science
Chemistry	Botany		Computer Application
Mathematics	Zoology		
Max 3	Max 2	Max 1	Max 1

B. Common Courses

Multi-Disciplinary 1	Value Added Course	Ability Enhancement Course	Skill Enhancement Course
Subject Groups	Subject Groups	Subject Groups	Subject Groups
Natural & Physical Science	Understanding India	MIL	
Mathematics, Statistics & Computer Applications	Environmental Science	English Usage (Communication)	
Library Information & Media Sciences	Digital & Technological Solutions		
Commerce & Management	Health & Wellness, Yoga Education, Sports & Fitness		
Humanities & Social Sciences			

Multi-Disciplinary 1		
Subject Groups	Subjects	Requirements
Natural & Physical Science	Physics & Astronomy, Chemistry, Biological Science, and Earth Science	<p><i>A Student can't choose a multidisciplinary subject if S/he has already studied that subject during class XI & XII</i></p> <p><i>The subject of these courses must not be among the core subjects the student has already chosen</i></p>
Mathematics, Statistics	Basic Mathematics and Statistics	
Computer Applications	Introductory Computer Applications and Programming, Information Technology	
Library Information & Media Sciences	Basic Information and Media, Mass Media and Communication	
Commerce & Management	Basic Business Management, Introductory Commerce	
Humanities & Social Sciences	Basic Economics, Political Science, History, Philosophy, and Psychology, Women's and Gender Studies	

LIST OF PREREQUISITES & REQUIREMENTS

Stream: Science		
Physical Science		
Subject	Prerequisites	Requirements
Chemistry	Chemistry & Math (XII Level)	None
Mathematics	Math (XII Level)	None
Physics	Physics & Math (XII Level)	Math

Stream: Science		
Biological Science & Anthropology		
Subject	Prerequisites	Requirements
Botany	Biology (XII Level)	Chemistry
Zoology	Biology & Chemistry (XII Level)	Chemistry

Stream: Science		
Earth & Environmental Science		
Subject	Prerequisites	Requirements
Geography	None	None

Stream: Science		
Computer & Information Science		
Subject	Prerequisites	Requirements
Computer Application	Science & Math (XII Level)	None

3. Bachelor's Degree in Commerce

The Bachelor's Degree in Commerce is a standalone course with the FYUGP structure. However, with this degree, one can have choice of Majors in (i) Accountancy, (ii) Finance, (iii) Human Resource Management, and (iv) Marketing Management. The Common Courses are same for all. Below, we show the Major options as well as the Common Courses for a Bachelor's Degree in Commerce.

A. Common Courses:

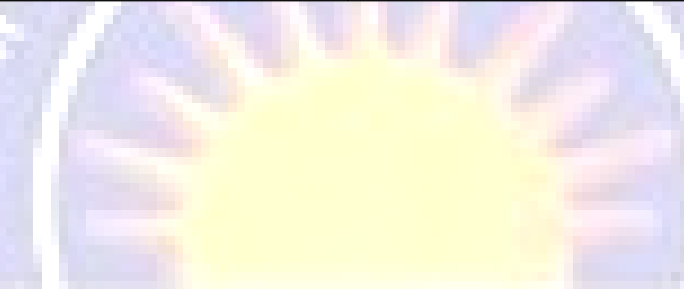
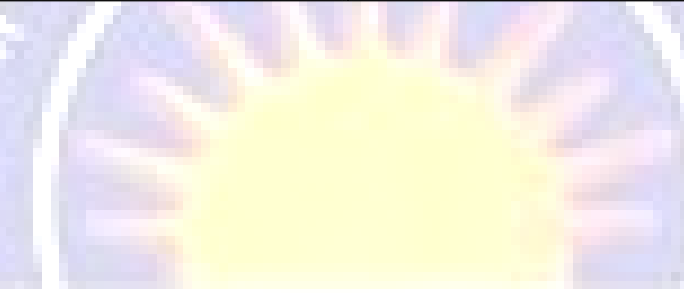
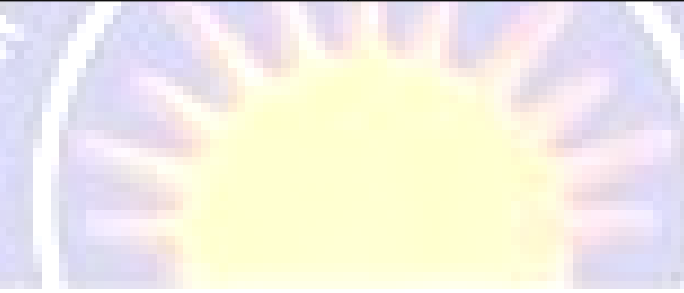
Credits	Semester	Common Courses									
10	I	Multidisciplinary 1 (Credit : 3)	VAC 1 (Credit : 3)	AEC 1 (Credit : 4)							
		Business Mathematics	Environmental Studies	English Communication							
10	II	Multidisciplinary 2 (Credit : 3)	SEC 1 (Credit : 3)	AEC 3 (Credit : 4)							
		Business Economics	IT in Business	Business Communication							
10	III	Multidisciplinary 3 (Credit : 3)	Internship (Credit : 4)	VAC 2 (Credit : 3)							
		Business Statistics	<i>On a chosen topic</i>	Trade & Commerce in India							
2	IV				SEC 2 (Credit : 2)						
					E-Commerce						
2	V							SEC 3 (Credit : 2)			
								New Venture Planning / E-Filing of Return			
2	VI										SEC 4 (Credit : 2)
											Business Etiquette & Soft Skill

B. Major: Accountancy

Major : Accountancy						
Credits	Semester	Core Courses (Credit per Course : 4)				
12	I	Core 1	Core 2	Core 3		
		Business Organisation & Management	Financial Accounting	Indian Financial System		
12	II	Core 4	Core 5	Core 6		
		Corporate Accounting	Principles & Practice of Management	Principles of Marketing		
12	III	Major 1	Major 2	Major 3		
		Advance Financial Accounting	Entrepreneurship	Business Laws		
20	IV	Major 4	Major 5	Major 6	Major 7	Minor 1
		Advance Corporate Accounting	Cost Accounting	Income Tax Laws & Practices	Fundamentals of Financial Management	Financial Market Operations
20	V	Major 8	Major 9	Major 10	Major 11	Minor 2
		Fundamentals of Investment	Indian Economy	Fundamentals of Investment	Indirect Taxes	Corporate Laws
20	VI	Major 12	Major 13	Major 14	Major 15	Minor 3
		Management Accounting	Operations Research in Business	Computerised Accounting	Audit & Assurance	Project Management

C. Major: Finance

Major : Finance						
Credits	Semester	Core Courses (Credit per Course : 4)				
12	I	Core 1	Core 2	Core 3		
		Business Organisation & Management	Financial Accounting	Indian Financial System		
12	II	Core 4	Core 5	Core 6		
		Corporate Accounting	Principles & Practice of Management	Principles of Marketing		
12	III	Major 1	Major 2	Major 3		
		Banking	Entrepreneurship	Business Laws		
20	IV	Major 4	Major 5	Major 6	Major 7	Minor 1
		Cost & Management	Financial Market Operations	Insurance	Fundamentals of Financial Management	Direct & Indirect Taxes
20	V	Major 8	Major 9	Major 10	Major 11	Minor 2
		Fundamentals of Investment	Indian Economy	Financial Services	Industrial Business	Corporate Laws
20	VI	Major 12	Major 13	Major 14	Major 15	Minor 3
		Treasury & Risk Management	Micro Finance	Marketing Services	Operations Research in Business	Project Management

D. Major: Human Resource Management

Major : Human Resource Management						
Credits	Semester	Core Courses (Credit per Course : 4)				
12	I	Core 1	Core 2	Core 3		
		Business Organisation & Management	Financial Accounting	Indian Financial System		
12	II	Core 4	Core 5	Core 6		
		Corporate Accounting	Principles & Practice of Management	Principles of Marketing		
12	III	Major 1	Major 2	Major 3		
		Human Resource Management	Entrepreneurship	Business Laws		
20	IV	Major 4	Major 5	Major 6	Major 7	Minor 1
		Industrial Relations	Labour Laws	Fundamentals of Financial Management	Cost & Management Accounting	Direct & Indirect Taxes
20	V	Major 8	Major 9	Major 10	Major 11	Minor 2
		Performance Management	International Business	Labour Welfare & Social Security	Indian Economy	Corporate Laws
20	VI	Major 12	Major 13	Major 14	Major 15	Minor 3
		Strategic Human Resource Management	Technology in Human Resource Management	Operations Research in Business	Training & Development	Project Management

Major: Marketing Management

Major : Marketing Management						
Credits	Semester	Core Courses (Credit per Course : 4)				
12	I	Core 1	Core 2	Core 3		
		Business Organisation & Management	Financial Accounting	Indian Financial System		
12	II	Core 3	Core 4	Core 5		
		Corporate Accounting	Principles & Practice of Management	Principles of Marketing		
12	III	Core 6	Core 7	Core 8		
		Advertising	Entrepreneurship	Business Laws		
20	IV	Major 1	Major 2	Major 3	Major 4	Minor 1
		Customer Relationship Management	Retail Management	Cost & Management Accounting	Fundamentals of Financial Management	Direct & Indirect Taxes
20	V	Major 5	Major 6	Major 7	Major 8	Minor 2
		Indian Economy	Consumer Behaviour	International Business	Brand Management	Corporate Laws
20	VI	Major 9	Major 10	Major 11	Major 12	Minor 3
		Marketing of Service	Operations Research in Business	Consumer Affair & Customer Care	Personal Selling & Salesmanship	Project Management

LIST OF PREREQUISITES & REQUIREMENTS

Stream: Commerce & Management		
Subject	Prerequisites	Requirements
Travel & Tourism Management	None	None

ADMISSION PROCEDURE:

For Higher Secondary (Xth+ Level Courses)

- Step 1: Visit Darpan Portal & Register
- Step 2: Visit College Website & Register
- Step 3: Publication of Merit List
- Step 4: Document verification & Spot Admission

For Degree (XIIth+ Level Courses)

- Step 1: Visit College Website & Register
- Step 2: Visit Samarth Portal & Register
- Step 3: Publication of Merit List
- Step 4: Document verification & Spot Admission

Note: A student needs to register on both Darpan Portal and College Website Separately for Admission in Higher Secondary courses.

Note: A student needs to register on both College Website & Samarth Portal Separately for Admission in Four Year Under-Graduate Programme.

Subject-wise Intake Capacity
Morigaon College : FYUGP : 2023-24

Sl. No.	Name of Discipline/Subject Group	Unique Code of Discipline/Subject	Discipline-Name	Major Seats in College	Minor Seats in College
1	Physical Science	CHE	Chemistry	30	150
2	Physical Science	MAT	Mathematics	50	100
3	Physical Science	PHY	Physics	30	100
4	Biological Science & Anthropology	BOT	Botany	40	100
5	Biological Science and Anthropology	ZOO	Zoology	60	100
6	Biological Science and Anthropology	ANT	Anthropology	30	120
7	Earth and Environmental Science	GGY	Geography	50	100
8	Computer & Information Science	CSC	Computer Science	-	50
9	MIL	HIN	Hindi	50	100
10	MIL	ASM	Assamese	80	220
11	Social Science	ECO	Economics	60	100
12	Social Science	PHI	Philosophy	40	70
13	Social Science	HIS	History	40	160
14	Social Science	PSC	Political Science	80	140
15	Social Science	EDU	Education	80	130
16	Social Science	SOC	Sociology	-	200
17	Other Language	ENG	English	60	140
18	Commerce	COM	Commerce &	200	-
19	Computer Application	BCA	Computer Application	50	-
20	Vocational Discipline	BVOC	Food Processing (Agriculture)	30	-
21	Vocational Discipline	BVOC	Mass Communication & Journalism	30	-

FEE STRUCTURE

Courses		Fees
HS I(Arts)	Boys	4310.00
	Girls	3710.00
HS I(Science)	Boys	4930.00
	Girls	4210.00
HS II(Arts)	Boys	4130.00
	Girls	3530.00
HS II(Science)	Boys	4750.00
	Girls	4030.00
Degree in Streams		
Degree in Arts (Major)		
SEM I/II		5055.00
SEM III/IV		4695.00
SEM V/VI		4695.00
Degree in Science (Major)		
SEM I/II(Sc)		5635.00
SEM III/IV(Sc)		5025.00
SEM V/VI(Sc)		5025.00
General (Non-Major)		
SEM I/II(A)		4935.00
SEM I/II(Sc)		5455.00
SEM III/IV(A)		4575.00
SEM III/IV(Sc)		4895.00
SEM V/VI(A)		4895.00
SEM V/VI(Sc)		4995.00